

Smart Digital Height Measurement System

Smt. Suma K G¹ Assistant professor ECE Dept
Bharatha B², Bhoomika B R³, Sampada M⁴, Darshan B S⁵
^{1,2,3,4,5}Electronics and Communication Engineering
Bapuji Institute of Engineering and Technology, Davangere.

Date of Submission: 20-10-2023

Date of Acceptance: 30-10-2023

ABSTRACT: Nowadays we have some difficulties in obtaining the height measurement that we want to measure. Even though, measuring tape is an easy option, but this kind of tool will have limitation of manual error. The Smart Digital Height Measurement System using Ultrasonic Sensor [1] and Arduino Uno as an innovative solution that enables accurate and convenient measurement of heights in various applications. This system utilizes an ultrasonic sensor coupled with an Arduino to provide a reliable and user-friendly method of measuring the height [2].

KEYWORDS: Ultrasonic Sensor, Arduino Uno and LCD display.

I. INTRODUCTION

In earlier days the measurements were generally occurring through measuring devices such as measuring tapes, rulers etc. In order to eliminate the errors, it requires to display the measured height in digital form.

Therefore, we use a proper display unit for measurement of height, such as sound waves which are known as ultrasonic waves using ultrasonic sensors and convert this sound wave for the measurement of various units such as height and distance. This technique of distance measurement using ultrasonic in air includes continuous pulse echo method. A burst of pulse is sent for transmission medium and is reflected by an object kept at specific distance. The time taken for the sound wave to propagate from transmitter to receiver is proportional to the distance of the object.

In this height measurement system, we have ultrasonic sensor HC-SR04 interfaced with Arduino Uno. Arduino will read it and sent it to the LCD Display. Ultrasonic sensors are very versatile in height measurement. They are also providing the cheapest solutions. Ultrasonic sensors are also quite fast for most of the common applications.

II. METHODOLOGY

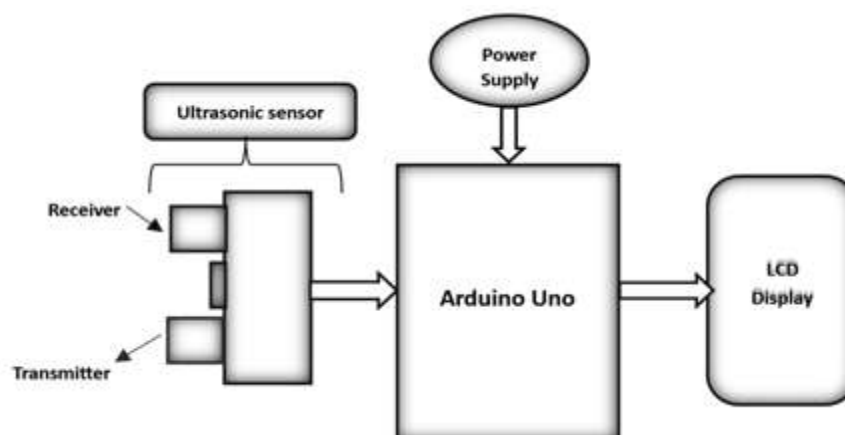

Fig.1 Block diagram

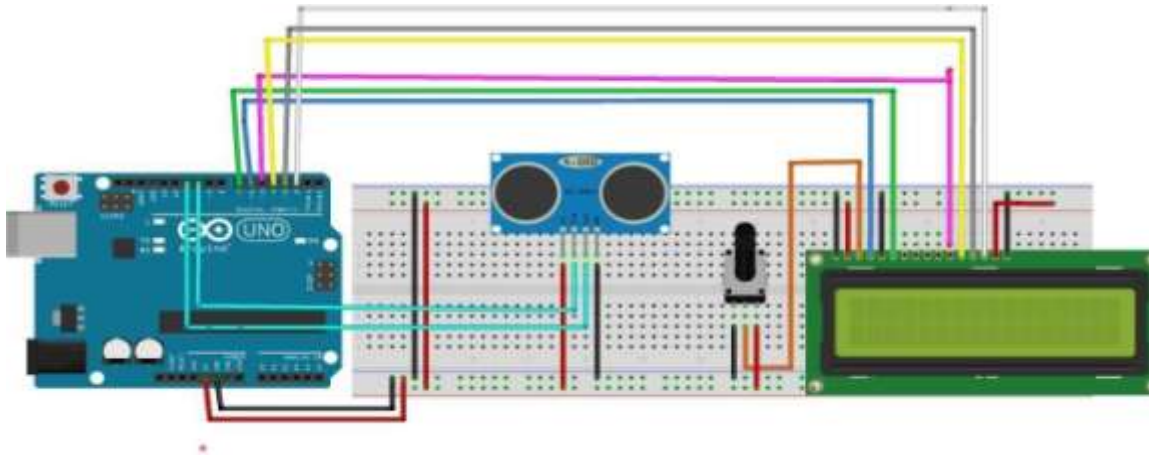

Fig.2 Schematic diagram

The Block diagram of smart digital height measurement system is shown in fig 1. It mainly consists of a Arduino uno, ultrasonic sensor, LCD display. The HC-SR04 ultrasonic sensor uses sonar to determine the height of an object. Then LCD display will show exact height of an object or person.

A.Arduino Uno: The Arduino Uno is a microcontroller board based on the ATmega328 (datasheet). It has 14 digital input/output pins (of which 6 can be used as PWM outputs), 6 analog

inputs, a 16 MHz crystal oscillator, a USB connection, a power jack, an ICSP header, and a reset button.

transmitter, receiver and the control circuit. The working principle of ultrasonic sensor is as follows:

- 1) High level signal is sent for 10us using Trigger.
- 2) The module sends eight 40 KHz signals automatically, and then detects whether pulse is received or not.
- 3) If the signal is received, then it is through high level.

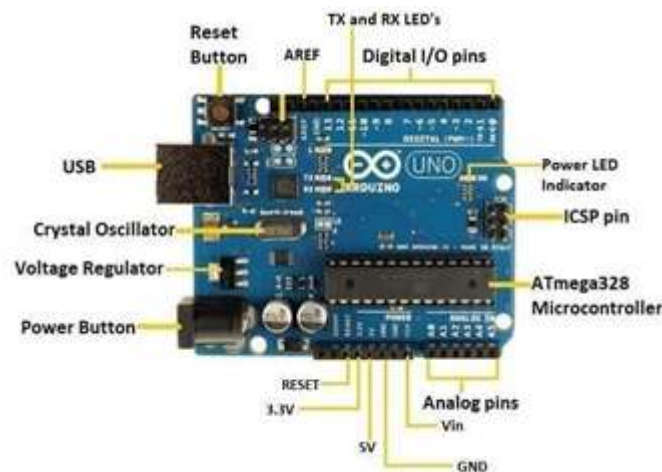

It contains everything needed to support the microcontroller; simply connect it to a computer with a USB cable or power it with a AC to DC adapter or battery to get started.

The time of high duration is the time between sending and receiving the signal.

$$\text{Distance} = (\text{Time} \times \text{Speed of Sound in Air } (340 \text{ m/s}))/2$$



Here we have divided the product of speed and time by 2 because the time is the total time it

B. Ultrasonic sensor. Ultrasonic sensor HCSR04[1] is used here to measure distance in range of 2cm-400cm with accuracy of 3mm. The sensor module consists of ultrasonic tool to reach the obstacle and return back. Thus the time to reach obstacle is just half the total time taken

C. LCD Display: To make the system user friendly a set of instructions are displayed on the LCD. Also the results are to be displayed after every measurement. For this purpose, we use a 16*2 LCD. It is a basic 16 character by 2line display. Black text on green background. Utilizes the extremely common HD44780 parallel interface chipset .11 general I/O pins are required to interface. Includes LED backlight. The microcontroller output is forwarded to the LCD. Interfacing of the microcontroller with 16X2 LCD is carried out. The LCD displays the measured quantity.



D. Potentiometer: Potentiometer is a device used to measure the internal resistance of a cell, to compare the EMF of two cells and potential difference across a resistor. Here which is used for brightness control.

III. IMPLEMENTATION

This system is mainly designed to detect or measure the height. Ultrasonic sensor measures the distance from reference level. Here reference level is taken as ground [4]. By taking input from the sensor, it is given to the Arduino controller. It converts analog data to digital data. After that microcontroller gives this output to LCD display. LCD displays measured height in centimeters.

A. Software Module: In this Arduino IDE is used for programming.

- B. Algorithm:**
- 1) Step1: Start
 - 2) Step2: Initialize all the modules
 - 3) Step3: Enter into while loop(o/p=high)
 - 4) Step4: Read ADC
 - 5) Step5: Compute height using multiplication factor
 - 6) Step6: Display the height
 - 7) Step7: Stop

IV. EXPERIMENTATION

The device is initialized at 180cm above the ground.

When a person stands under the device, the height of the person is displayed on the LCD display.



In the above figure we can see that when there is no person, the system will show 0cm. While a person stands under this device it was showing height of that person as 152cm.

V. CONCLUSION

A smart height measuring system has been developed in this project. It may be commonly used in height measurement equipment. This digital height meter is easy to construct and cheap. It can be helpful in military recruitment and in hospitals. Overall, the digital measurement of height using ultrasonic technology offers benefits such as accuracy, non-contact measurement, and versatility, making it valuable in numerous fields and applications.

REFERENCES:

- [1] <https://www.fierceelectronics.com/sensors/whatultrasonic-sensor>
- [2] <https://www.instructables.com/SONARHeight-Measuring-Instrument/>
- [3] Wang and W. Chen, "The human-height measurement scheme by using image processing techniques," 2012 International Conference on Information Security and Intelligent Control, 2012, pp.186-189, doi:10.1109/ISIC.2012.6449737.
- [4] Dianyuan Han and Chengduan Wang, "Tree height measurement based on image processing embedded in smart mobile phone," 2011 International Conference on Multimedia Technology, 2011, pp.32933296, doi:10.1109/ICMT.2011.6002029.